



INTERNATIONAL APPLICATION PUBLISHED UNDER THE PATENT COOPERATION TREATY (PCT)

(51) International Patent Classification ⁶ :- E04F 15/04	A1	(11) International Publication Number: WO 99/40273 (43) International Publication Date: 12 August 1999 (12.08.99)
<p>(21) International Application Number: PCT/SE99/00128</p> <p>(22) International Filing Date: 1 February 1999 (01.02.99)</p> <p>(30) Priority Data: 9800311-4 4 February 1998 (04.02.98) SE</p> <p>(71) Applicant (for all designated States except US): PERSTORP FLOORING AB [SE/SE]; Strandridaregatan 8, S-231 25 Trelleborg (SE).</p> <p>(72) Inventor; and (75) Inventor/Applicant (for US only): OLOFSSON, Ola [SE/SE]; Torupsgatan 23, S-231 66 Trelleborg (SE).</p> <p>(74) Agent: STENBERG, Yngve; Perstorp AB, S-284 80 Perstorp (SE).</p>	<p>(81) Designated States: AL, AM, AT, AU, AZ, BA, BB, BG, BR, BY, CA, CH, CN, CU, CZ, DE, DK, EE, ES, FI, GB, GD, GE, GH, GM, HR, HU, ID, IL, IN, IS, JP, KE, KG, KP, KR, KZ, LC, LK, LR, LS, LT, LU, LV, MD, MG, MK, MN, MW, MX, NO, NZ, PL, PT, RO, RU, SD, SE, SG, SI, SK, SL, TJ, TM, TR, TT, UA, UG, US, UZ, VN, YU, ZW, ARIPO patent (GH, GM, KE, LS, MW, SD, SZ, UG, ZW), Eurasian patent (AM, AZ, BY, KG, KZ, MD, RU, TJ, TM), European patent (AT, BE, CH, CY, DE, DK, ES, FI, FR, GB, GR, IE, IT, LU, MC, NL, PT, SE), OAPI patent (BF, BJ, CF, CG, CI, CM, GA, GN, GW, ML, MR, NE, SN, TD, TG).</p> <p>Published <i>With international search report. Before the expiration of the time limit for amending the claims and to be republished in the event of the receipt of amendments. In English translation (filed in Swedish).</i></p>	

(54) Title: GUIDING MEANS AT A JOINT

(57) Abstract

A guiding means at a joint comprising groove (1) and tenon (2) preferably intended to be joined with glue. The tenon (2) and/or groove (1) includes guiding wedges (3).

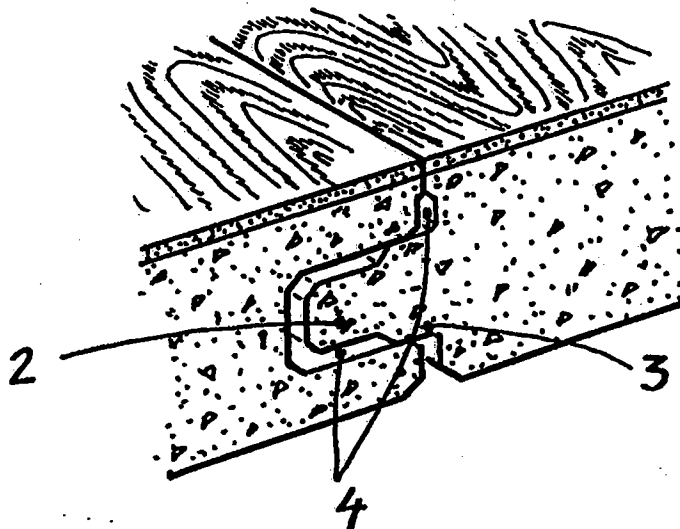

FOR THE PURPOSES OF INFORMATION ONLY

Codes used to identify States party to the PCT on the front pages of pamphlets publishing international applications under the PCT.

AL	Albania	ES	Spain	LS	Lesotho	SI	Slovenia
AM	Armenia	FI	Finland	LT	Lithuania	SK	Slovakia
AT	Austria	FR	France	LU	Luxembourg	SN	Senegal
AU	Australia	GA	Gabon	LV	Latvia	SZ	Swaziland
AZ	Azerbaijan	GB	United Kingdom	MC	Monaco	TD	Chad
BA	Bosnia and Herzegovina	GE	Georgia	MD	Republic of Moldova	TG	Togo
BB	Barbados	GH	Ghana	MG	Madagascar	TJ	Tajikistan
BE	Belgium	GN	Guinea	MK	The former Yugoslav Republic of Macedonia	TM	Turkmenistan
BF	Burkina Faso	GR	Greece	ML	Mali	TR	Turkey
BG	Bulgaria	HU	Hungary	MN	Mongolia	TT	Trinidad and Tobago
BJ	Benin	IE	Ireland	MR	Mauritania	UA	Ukraine
BR	Brazil	IL	Israel	MW	Malawi	UG	Uganda
BY	Belarus	IS	Iceland	MX	Mexico	US	United States of America
CA	Canada	IT	Italy	NE	Niger	UZ	Uzbekistan
CF	Central African Republic	JP	Japan	NL	Netherlands	VN	Viet Nam
CG	Congo	KE	Kenya	NO	Norway	YU	Yugoslavia
CH	Switzerland	KG	Kyrgyzstan	NZ	New Zealand	ZW	Zimbabwe
CI	Côte d'Ivoire	KP	Democratic People's Republic of Korea	PL	Poland		
CM	Cameroon	KR	Republic of Korea	PT	Portugal		
CN	China	KZ	Kazakstan	RO	Romania		
CU	Cuba	LC	Saint Lucia	RU	Russian Federation		
CZ	Czech Republic	LI	Liechtenstein	SD	Sudan		
DE	Germany	LK	Sri Lanka	SE	Sweden		
DK	Denmark	LR	Liberia	SG	Singapore		
EE	Estonia						

Guiding means at a joint.

The present invention relates to a guiding means at a joint comprising groove and tenon, preferably intended to be joined with glue.

Prefabricated floorboards which at their edges are provided with groove and tenon are well known nowadays. As these are very easy to install it is possible for the normal handy man to achieve this. These type of floors can be constituted of massive wood, fibre board or particle board. These are often provided with a surface layer, such as lacquer or some sort of laminate. The boards are most often installed by gluing them together via their groove and tenon. It is desired to join the separate boards so closely that the joint becomes practically invisible, which increases the moisture resistance radically. The usable life of the installed floor is hereby also increased. In order to achieve a tight joint, it is essential that glue is used excessively. The clearance in the joint will therefore have to be relatively large in order to be able to force the boards together without having to use special equipment due to the forces that would be needed otherwise. A too small clearance will cause a hydraulic resistance caused by the glue captured inside the groove during the joining. The clearance needed will however cause a random discrepancy in the levels between adjacent floorboards. This discrepancy in levels will lead to an increased wear at the joint and that moisture may penetrate the joint. The decorative wear layer, often constituted by lacquer or laminate will hereby often be worn down closest to the joint. The wood fibre will hereby be naked closest to the joint, which in addition to being unsightly also may cause the fibres to swell when exposed to moisture. This causes the surface layer to rise closest to the edges whereby these edges will be exposed to further wear, which will decrease the useful life of the floor radically.

It has, through the present invention, quite unexpectedly been possible to solve the above mentioned problems so that the risk for error during installation is radically reduced, whereby the average usable life of the floor, with a guiding means according to the present invention, is considerably increased. Accordingly, the invention relates to a guiding means at a joint comprising groove and tenon preferably intended to be joined with glue. The invention is characterised in that the tenon and/or groove includes guiding wedges. The guiding means preferably forms a part of boards intended to, together form a floor. The core of the boards is constituted by a fibre board or a particle board. At least the upper side of the board is constituted by a decorative thermosetting laminate. The fitting clearance between the tenon and the groove includes a first fitting clearance and a second, guiding, fitting clearance. The second, guiding, fitting clearance is obtained through the guiding

wedges. The first fitting clearance comprises the main part of the fit and the second, guiding fitting clearance comprises a smaller part of the fit. The first fitting clearance is in the range 0.1 - 1 mm, preferably 0.1 - 0.5 mm, while the second, guiding, fitting clearance is in the range 0.01 - 0.2 mm, preferably 0.02 - 0.1 mm.

According to one embodiment of the invention the guiding wedges are arranged perpendicular to the extension of the joint.

According to another embodiment of the invention the guiding wedges are arranged parallel to the extension of the joint.

The surfaces of the joint is provided with recesses so that cavities are formed in the joint. The cavities are intended to receive the glue used during the joining.

The invention is further illustrated together with enclosed figures showing different embodiments of the invention whereby,

-figure 1 shows, in perspective view, a first embodiment of a guiding means at a joint, according to the invention.

-figure 2 shows, in perspective view, the embodiment from figure 1 after assembly.

-figure 3 shows, in perspective view, a second embodiment of a guiding means at a joint, according to the invention.

-figure 4 shows, in perspective view, a third embodiment of a guiding means at a joint, according to the invention.

Accordingly, figure 1 shows, in perspective view seen from above, a first embodiment of a guiding means at a joint according to the invention. The guiding means comprises groove 1 and tenon 2 which usually is intended to be joined by using glue. The tenon 2 comprises guiding wedges 3 on the upper and lower sides. The fitting clearance between the groove 1 and tenon 2 includes a first and a second, guiding, fitting clearance, which second, guiding, fitting clearance is obtained by the guiding wedges 3. The first fitting clearance forms the main part of the fit while the second, guiding, fitting clearance forms a smaller part of the fit. The first fitting clearance is approximately 0.2 mm while the second, guiding fitting clearance is approximately 0.05 mm. The guiding wedges 3 are arranged parallel to the extension of the joint. The same embodiment is shown assembled in figure 2.

The respective surfaces of the joint are provided with recesses so that cavities 4 are formed in the joint. The cavities 4 are intended to receive the glue used at the assembly. The guiding means comprises a part of boards intended to, together form a floor whereby the core of the board is constituted by fibre board or a particle board and at least the upper side of the board is constituted by a decorative thermosetting laminate.

Figure 3 shows, in perspective view seen aslant from above, a second embodiment of a guiding means at a joint, according to the invention. The embodiment conforms in the main with the one described in connection to figure 1 and 2. The tenon 2 is, however, provided with guiding wedges arranged perpendicularly to the extension of the joint.

Figure 4 shows, in perspective view seen aslant from above, a third embodiment of a guiding means at a joint, according to the invention. The embodiment is shown assembled. The embodiment corresponds in the main to the one described in connection to figure 1 and 2, the tenon 2 is however provided with guiding wedges 3 only at the lower side.

The invention is not limited by the embodiments shown since these can varied in different ways within the scope of the invention. Guiding wedges 3 can, for example, be arranged inside the groove 1. If these guiding wedges 3 are parallel to the extension of the joint, they are suitably arranged in the bottom of the groove 1 while they can be given a shape similar to the one shown in figure 3 if they are arranged perpendicularly to extension of the joint.

CLAIMS

1. A guiding means at a joint comprising groove (1) and tenon (2) preferably intended to be joined with glue characterised in that the tenon (2) and/or groove (1) includes guiding wedges (3).
2. A guiding means according to claim 1 characterised in that the fitting clearance between the tenon (1) and the groove (2) includes a first fitting clearance and a second, guiding, fitting clearance, which second, guiding, fitting clearance is obtained through the guiding wedges (3), whereby the first fitting clearance comprises the main part of the fit and the second, guiding fitting clearance comprises a smaller part of the fit, that the first fitting clearance is in the range 0.1 - 1 mm, preferably 0.1 - 0.5 mm, while the second, guiding, fitting clearance is in the range 0.01 - 0.2 mm, preferably 0.02 - 0.1 mm.
3. A guiding means according to claim 1 or 2 characterised in that the guiding wedges (3) are arranged perpendicular to the extension of the joint.
4. A guiding means according to claim 1 or 2 characterised in that the guiding wedges (3) are arranged parallel to the extension of the joint.
5. A guiding means according to any of the claims 1 - 4 characterised in that the surfaces of the joint is provided with recesses so that cavities (4) are formed in the joint, which cavities (4) are intended to receive the glue used during the joining.
6. A guiding means according to any of the claims 1 - 5 characterised in that the guiding means forms a part of boards intended to, together form a floor, whereby the core of the boards is constituted by a fibre board or a particle board and that at least the upper side of the board is constituted by a decorative thermosetting laminate.

Fig. 1

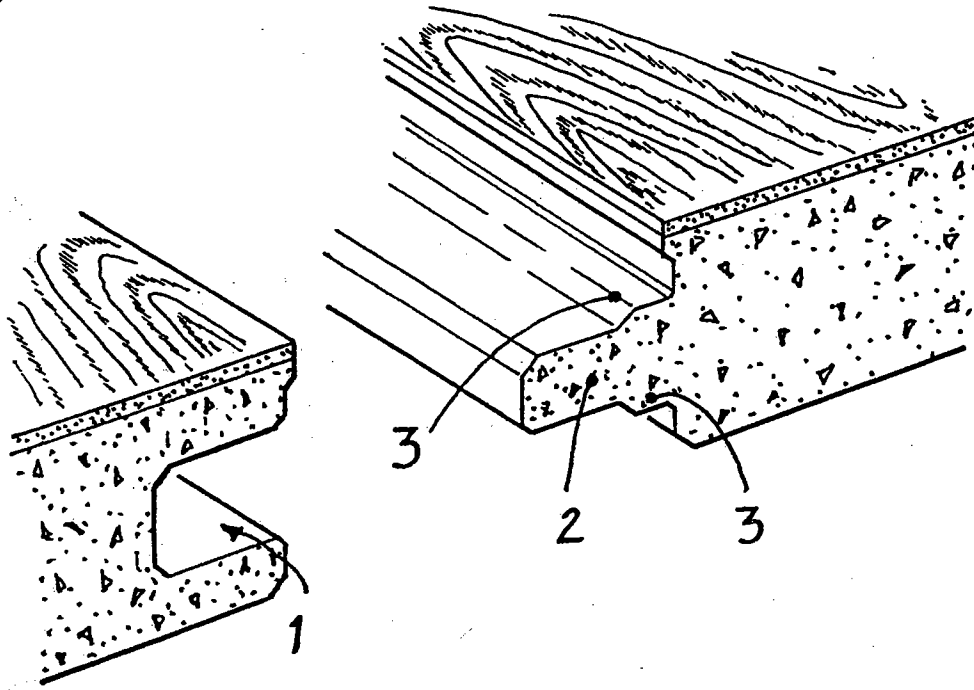

Fig. 2

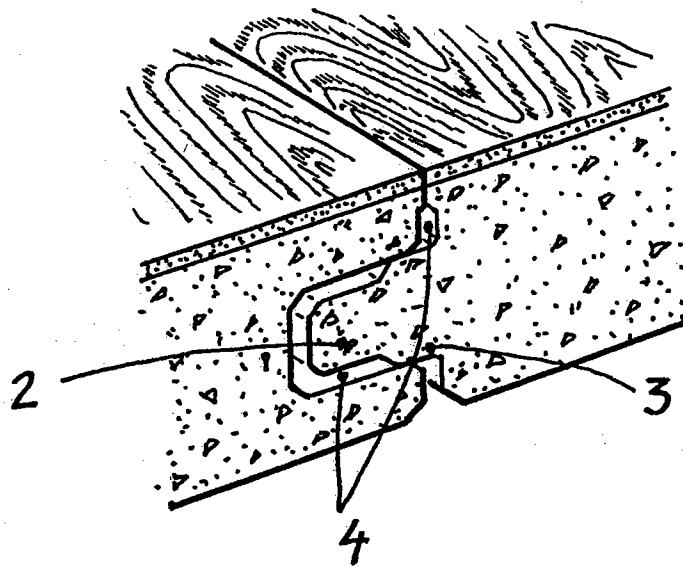

Fig. 3

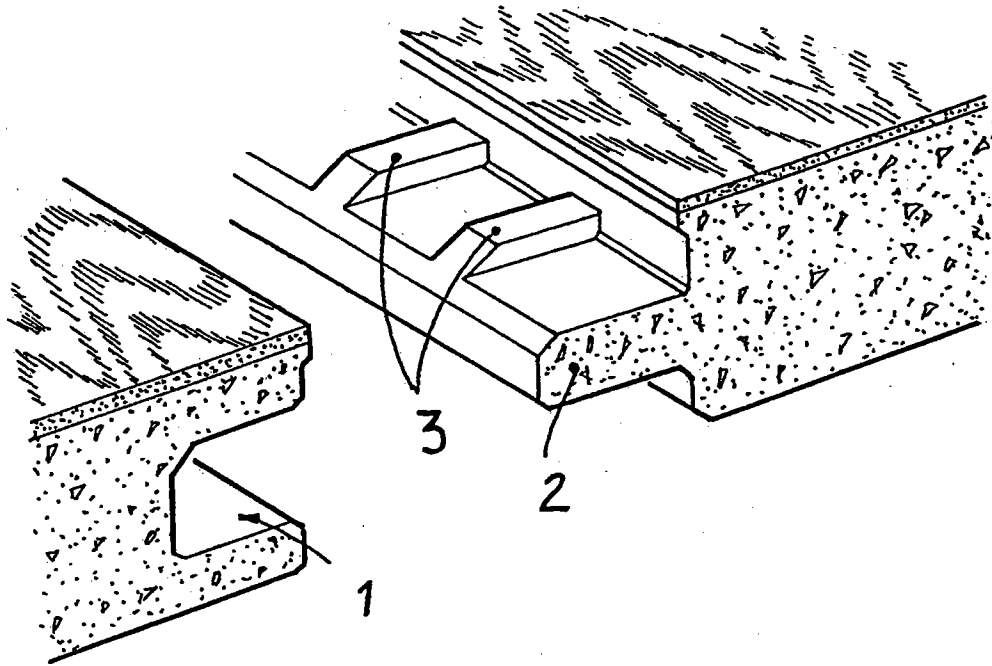
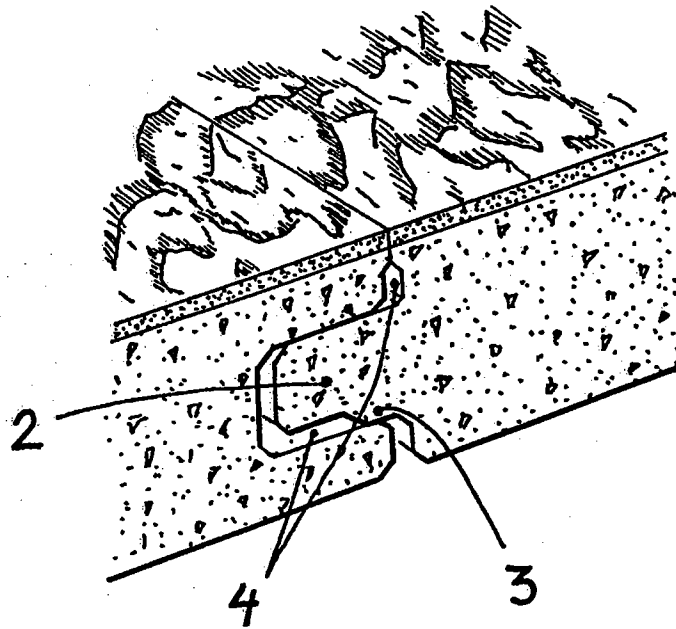

Fig. 4



INTERNATIONAL SEARCH REPORT

International application No.

PCT/SE 99/00128

A. CLASSIFICATION OF SUBJECT MATTER

IPC6: E04F 15/04
According to International Patent Classification (IPC) or to both national classification and IPC

B. FIELDS SEARCHED

Minimum documentation searched (classification system followed by classification symbols)

IPC6: E04F

Documentation searched other than minimum documentation to the extent that such documents are included in the fields searched
SE,DK,FI,NO classes as above

Electronic data base consulted during the international search (name of data base and, where practicable, search terms used)

WPI, EPODOC

C. DOCUMENTS CONSIDERED TO BE RELEVANT

Category*	Citation of document, with indication, where appropriate, of the relevant passages	Relevant to claim No.
X	US 5165816 A (A.V. PARASIN), 24 November 1992 (24.11.92)	1,4
Y		5,6
A		2,3
	--	
Y	WO 9747834 A1 (UNILIN BEHEER B.V.), 18 December 1997 (18.12.97)	5,6
A		1-4
	--	
A	US 752694 A (J.G.F. LUND), 23 February 1904 (23.02.04)	1-6
	--	

Further documents are listed in the continuation of Box C.

See patent family annex.

* Special categories of cited documents:

"A" document defining the general state of the art which is not considered to be of particular relevance

"E" earlier document but published on or after the international filing date

"I" document which may throw doubts on priority claim(s) or which is cited to establish the publication date of another citation or other special reason (as specified)

"O" document referring to an oral disclosure, use, exhibition or other means

"P" document published prior to the international filing date but later than the priority date claimed

"T" later document published after the international filing date or priority date and not in conflict with the application but cited to understand the principle or theory underlying the invention

"X" document of particular relevance: the claimed invention cannot be considered novel or cannot be considered to involve an inventive step when the document is taken alone

"Y" document of particular relevance: the claimed invention cannot be considered to involve an inventive step when the document is combined with one or more other such documents, such combination being obvious to a person skilled in the art

"&" document member of the same patent family

Date of the actual completion of the international search

17 May 1999

Date of mailing of the international search report

06-06-1999

Name and mailing address of the ISA
Swedish Patent Office
Box 5055, S-102 42 STOCKHOLM
Facsimile No. +46 8 666 02 86

Authorized officer
Johan Winther
Telephone No. +46 8 782 25 00

INTERNATIONAL SEARCH REPORT

International application No.

PCT/SE 99/00128

C (Continuation). DOCUMENTS CONSIDERED TO BE RELEVANT

Category*	Citation of document, with indication, where appropriate, of the relevant passages	Relevant to claim No.
A	WO 9627721 A1 (PERSTORP FLOORING AB), 12 Sept 1996 (12.09.96) ----- -----	1-6

INTERNATIONAL SEARCH REPORT

Information on patent family members

International application No.

PCT/SE 99/00128

Patent document cited in search report	Publication date	Patent family member(s)	Publication date
US 5165816 A	24/11/92	CA 2036029 A,C GB 2269875 A,B	09/08/92 23/02/94
WO 9747834 A1	18/12/97	AU 3256997 A BE 1010339 A BE 1010487 A BG 102230 A CA 2226286 A CN 1195386 A CZ 9800391 A DE 29710175 U EP 0843763 A NO 980569 A PL 324923 A SI 9720009 A SK 16398 A	07/01/98 02/06/98 06/10/98 30/09/98 18/12/97 07/10/98 12/08/98 14/08/97 27/05/98 10/02/98 22/06/98 31/08/98 09/09/98
US 752694 A	23/02/04	NONE	
WO 9627721 A1	12/09/96	AU 4960096 A BR 9607272 A CA 2213757 A CN 1177390 A EP 0768929 A EP 0813641 A JP 10502303 T JP 11501377 T NO 974110 A SE 9500810 D	23/09/96 23/06/98 12/09/96 25/03/98 23/04/97 29/12/97 03/03/98 02/02/99 06/11/97 00/00/00